



SKYHAWK

SURVEILLANCE

SATA Product Manual

Standard models

ST8000VX002
ST6000VX011
ST4000VX005
ST3000VX017
ST2000VX012

Standard Models

ST8000VX008
ST6000VX010
ST4000VX013
ST3000VX016
ST2000VX015

100870481, Rev. A
Gen 17 - July 2020

Document Revision History

Revision	Date	Pages affected
Rev. A	07/01/2020	Initial release.

© 2020 Seagate Technology LLC. All rights reserved.

Publication number: 100870481, Rev. A July 2020

Seagate, Seagate Technology and the Spiral logo are registered trademarks of Seagate Technology LLC in the United States and/or other countries. SkyHawk and SeaTools are either trademarks or registered trademarks of Seagate Technology LLC or one of its affiliated companies in the United States and/or other countries. All other trademarks or registered trademarks are the property of their respective owners.

No part of this publication may be reproduced in any form without written permission of Seagate Technology LLC.

Call 877-PUB-TEK1 (877-782-8351) to request permission.

When referring to drive capacity, one gigabyte, or GB, equals one billion bytes and one terabyte, or TB, equals one trillion bytes. Your computer's operating system may use a different standard of measurement and report a lower capacity. In addition, some of the listed capacity is used for formatting and other functions, and thus will not be available for data storage. Actual quantities will vary based on various factors, including file size, file format, features and application software. Actual data rates may vary depending on operating environment and other factors. The export or re-export of hardware or software containing encryption may be regulated by the U.S. Department of Commerce, Bureau of Industry and Security (for more information, visit www.bis.doc.gov), and controlled for import and use outside of the U.S. Seagate reserves the right to change, without notice, product offerings or specifications.

Contents

Seagate® Technology Support Services	5
---	----------

1.0 Introduction	6
1.1 About the SATA interface	7

2.0 Drive Specifications	8
2.1 Specification summary tables	8
2.2 Formatted capacity	10
2.2.1 LBA mode	10
2.3 Default logical geometry	10
2.4 Recording and interface technology	10
2.5 Physical characteristics	11
2.6 Start/stop times	11
2.7 Power specifications	12
2.7.1 Power consumption	12
2.7.2 Conducted noise	12
2.7.3 Voltage tolerance	13
2.7.4 Power-management modes	13
2.8 Environmental specifications	14
2.8.1 Ambient Temperature	14
2.8.2 Temperature gradient	14
2.8.3 Humidity	14
2.8.4 Altitude	15
2.8.5 Shock	15
2.8.6 Vibration	15
2.9 Acoustics	16
2.9.1 Test for Prominent Discrete Tones (PDTs)	16
2.10 Electromagnetic immunity	16
2.11 Warranty	17
2.11.1 Data loss under power interruption with write cache enabled	17
2.11.2 Storage	17
2.11.3 HDD and SSD Regulatory Compliance and Safety	17
2.11.4 Safety certification	17
2.12 Corrosive environment	17

3.0	Configuring and Mounting the Drive	18
3.1	Handling and static-discharge precautions	18
3.2	Configuring the drive	18
3.3	SATA cables and connectors	18
3.4	Drive mounting	19

4.0	SATA Interface	21
4.1	Hot-Plug compatibility	21
4.2	SATA device plug connector pin definitions	21
4.3	Supported ATA commands	22
4.3.1	Identify Device command	24
4.3.2	Set Features command	29
4.3.3	S.M.A.R.T. commands	30

Figures

Figure 1	Location of the HDA temperature check point	14
Figure 2	Attaching SATA cabling.....	18
Figure 3	Mounting dimensions (4TB, 3TB & 2TB models).....	19
Figure 4	Mounting dimensions (8TB & 6TB models).....	20

Seagate® Technology Support Services

For Seagate Product Support, visit: <https://www.seagate.com/support>

For Seagate Compliance, Safety, and Disposal, visit: <https://www.seagate.com/support>

For Firmware Download and Tools Download for Secure Erase, visit: <https://www.seagate.com/support/downloads/>

For information regarding online support and services, visit: <http://www.seagate.com/contacts/>

For information regarding Warranty Support, visit: <http://www.seagate.com/support/warranty-and-replacements/>

For information regarding data recovery services, visit: <http://www.seagate.com/services-software/recover/>

For Seagate OEM and Distribution partner and Seagate reseller portal, visit: <http://www.seagate.com/partners>

1.0 Introduction

This manual describes the functional, mechanical and interface specifications for the following Seagate® Skyhawk and model drives:

Standard models	Standard models
ST8000VX002	ST8000VX008
ST6000VX011	ST6000VX010
ST4000VX005	ST4000VX013
ST3000VX017	ST3000VX016
ST2000VX012	ST2000VX015

These drives provide the following key features:

- 1M hour MTBF - designed for high write duty cycle across SkyHawk
- ATA AV Command support - streaming video command support across SkyHawk
- Best-in-class acoustic performance means virtually silent operation
- Built-in error recovery for non-stop video streaming
- Compliant with RoHS requirements in China and Europe
- Full-track multiple-sector transfer capability without local processor intervention
- Idle3 power mode support
- Low activity power
- Low-RPM spindle speed
- Native Command Queuing with command ordering to increase performance in demanding applications
- Performance-tuned for seamless video applications
- Reliability for 24x7 video surveillance applications
- Rotational Vibration - mitigation of system level rotational vibration inside SkyHawk
- SeaTools diagnostic software performs a drive self-test that eliminates unnecessary drive returns.
- State-of-the-art cache and on-the-fly error-correction algorithms
- Streaming video optimization - consistent command completion times & ERC support across SkyHawk
- Support for S.M.A.R.T. drive monitoring and reporting
- Supports "8+" drive bays
- Supports ATA8 streaming commands
- Supports latching SATA cables and connectors
- Supports up to 64 HD cameras for recording and playback
- Thermal monitoring and reporting for 24x7 operations
- Transient power on management - $\leq 1.8A$ spin-up current
- Uncompromising reliability supports flexible surveillance design with case temperatures up to 70°C
- Workload ratings of 180TB/year
- Worldwide Name (WWN) capability uniquely identifies the drive

1.1 About the SATA interface

The Serial ATA (SATA) interface provides several advantages over the traditional (parallel) ATA interface. The primary advantages include:

- Easy installation and configuration with true plug-and-play connectivity. It is not necessary to set any jumpers or other configuration options.
- Thinner and more flexible cabling for improved enclosure airflow and ease of installation.
- Scalability to higher performance levels.

In addition, SATA makes the transition from parallel ATA easy by providing legacy software support. SATA was designed to allow users to install a SATA host adapter and SATA disk drive in the current system and expect all of the existing applications to work as normal.

The SATA interface connects each disk drive in a point-to-point configuration with the SATA host adapter. There is no master/slave relationship with SATA devices like there is with parallel ATA. If two drives are attached on one SATA host adapter, the host operating system views the two devices as if they were both “masters” on two separate ports. This essentially means both drives behave as if they are Device 0 (master) devices.

The SATA host adapter and drive share the function of emulating parallel ATA device behavior to provide backward compatibility with existing host systems and software. The Command and Control Block registers, PIO and DMA data transfers, resets, and interrupts are all emulated.

The SATA host adapter contains a set of registers that shadow the contents of the traditional device registers, referred to as the Shadow Register Block. All SATA devices behave like Device 0 devices. For additional information about how SATA emulates parallel ATA, refer to the “Serial ATA International Organization: Serial ATA Revision 3.0”. The specification can be downloaded from www.sata-io.org.

Note

The host adapter may, optionally, emulate a master/slave environment to host software where two devices on separate SATA ports are represented to host software as a Device 0 (master) and Device 1 (slave) accessed at the same set of host bus addresses. A host adapter that emulates a master/slave environment manages two sets of shadow registers. This is not a typical SATA environment.

2.0 Drive Specifications

Unless otherwise noted, all specifications are measured under ambient conditions, at 25°C, and nominal power. For convenience, the phrases *the drive* and *this drive* are used throughout this manual to indicate the following drive models

Standard models	Standard models
ST8000VX002	ST8000VX008
ST6000VX011	ST6000VX010
ST4000VX005	ST4000VX013
ST3000VX017	ST3000VX016
ST2000VX012	ST2000VX015

2.1 Specification summary tables

The specifications listed in [Table 1](#) are for quick reference.

For details on specification measurement or definition, refer to the appropriate section of this manual.

Table 1 Drive specifications summary

Drive Specification*	ST8000VX002, ST8000VX008	ST6000VX010, ST6000VX011	ST4000VX005, ST4000VX013	ST3000VX016, ST3000VX017	ST2000VX012, ST2000VX015
Formatted capacity (512 bytes/sector)**	8000GB (8TB)	6000GB (6TB)	4000GB (4TB)	3000GB (3TB)	2000GB (2TB)
Guaranteed sectors	15,628,053,168	11,721,045,168	7,814,037,168	5,860,533,168	3,907,029,168
Heads	8		4		2
Disks	4		2		1
Bytes per sector (emulated at 512-byte sectors)	4096 (physical)				
Default sectors per track	63				
Default read/write heads	16				
Default cylinders	16,383				
Recording density	2197 kB/in				
Track density (avg)	540 ktracks/in				
Areal density (avg)	1186 Gb/in ²	900 Gb/in ²	1186 Gb/in ²	900 Gb/in ²	1186 Gb/in ²
SATA interface transfer rate	600 MB/s				
Maximum data transfer rate	180 MB/s				
ATA data-transfer modes supported	PIO modes: 0 to 4 Multiword DMA modes: 0 to 2 Ultra DMA modes 0 to 6				
Cache buffer	256MB				
Height	26.1mm / 1.028 in (max)		20.20mm / 0.795 in (max)		
Width	101.6mm (± 0.25) / 4.0 in (± 0.010)				
Length	146.99mm / 5.787 in (max)				
Weight (typical)	630g / 1.389 lb	610g / 1.345 lb	490g / 1.08 lb		415g / 0.915 lb
Average latency	6.0 ms				
Power-on to ready (typ)	15.0s		10.0s		8.0s
Standby to ready (typ)	15.0s		10.0s		8.0s
Startup current (typical) 12V	1.8A				1.1A
Voltage tolerance (including noise)	5V ±5% 12V ±10%				
Non-Operating (Ambient °C)	-40° to 70°				

Table 1 Drive specifications summary (continued)

Drive Specification*	ST8000VX002, ST8000VX008	ST6000VX010, ST6000VX011	ST4000VX005, ST4000VX013	ST3000VX016, ST3000VX017	ST2000VX012, ST2000VX015
Operating ambient temperature (min °C) #	0°				
Operating temperature (drive case max °C)	70°†				
Temperature gradient	20°C per hour max (operating) 30°C per hour max (non-operating)				
Relative humidity	5% to 90% (operating) 5% to 95% (non-operating)				
Relative humidity gradient (max)	30% per hour				
Wet bulb temperature (max)	30°C max (operating) 40°C max (non-operating)				
Altitude, operating	-304m to 3048m (-1000 ft to 10,000 ft)				
Altitude, non-operating (below mean sea level, max)	-304m to 12,192m (-1000 ft to 40,000+ ft)				
Operational shock (max)	80 Gs (read) / 70 Gs (write) at 2ms				
Non-operational shock (max)	300 Gs at 2ms				350 Gs at 2ms
Vibration, operating	10Hz to 22Hz: 0.25 Gs, Limited displacement 22Hz to 350Hz: 0.50 Gs 350Hz to 500Hz: 0.25 Gs				
Vibration, non-operating	5Hz to 22Hz: 3.0 Gs 22Hz to 350Hz: 3.0 Gs 350Hz to 500Hz: 3.0 Gs				
Drive acoustics, sound power					
Idle***	2.6 bels (typical) 2.7 bels (max)				
Seek	2.7 bels (typical) 2.8 bels (max)				
Non-recoverable read errors	1 per 10 ¹⁴ bits read				
Rated workload	Average annualized workload rating: <180TB/year. The specifications for the product assumes the I/O workload does not exceed the average annualized workload rate limit of 180TB/year. Workloads exceeding the annualized rate may degrade and impact reliability as experienced by the particular application. The average annualized workload rate limit is in units of TB per calendar year.				
Warranty	To determine the warranty for a specific drive, use a web browser to access the following web page: http://www.seagate.com/support/warranty-and-replacements/ From this page, click on "Is my Drive under Warranty". Users will be asked to provide the drive serial number, model number (or part number) and country of purchase. The system will display the warranty information for the drive.				
Load/unload cycles (at 25°C, 50% rel. humidity)	600,000				
Supports hotplug operation per the Serial ATA Revision 3.2 specification	Yes				

* All specifications above are based on native configurations.

** One GB equals one billion bytes and 1TB equals one trillion bytes when referring to hard drive capacity. Accessible capacity may vary depending on operating environment and formatting.

*** During periods of drive idle, some offline activity may occur according to the S.M.A.R.T. specification, which may increase acoustic and power to operational levels.

† Seagate does not recommend operating at sustained case temperatures above 60°C. Operating at higher temperatures will reduce useful life of the product.

The operating case temperature is 0 to 70°C (32 to 158°F). The recommended measure location can be found in [Section 3.4 Figure 3 & 4](#).

Note

If the drive is powered-off before issuing flush cache command, in some instances, the end user data in the DRAM cache might not be committed to the disk.

2.2 Formatted capacity

Model	Formatted capacity*	Guaranteed sectors	Bytes per sector
8TB	8000GB	15,628,053,168	4096
6TB	6000GB	11,721,045,168	
4TB	4000GB	7,814,037,168	
3TB	3000GB	5,860,533,168	
2TB	2000GB	3,907,029,168	

*One GB equals one billion bytes and 1TB equals one trillion bytes when referring to hard drive capacity. Accessible capacity may vary depending on operating environment and formatting.

2.2.1 LBA mode

When addressing these drives in LBA mode, all blocks (sectors) are consecutively numbered from 0 to $n-1$, where n is the number of guaranteed sectors as defined above.

See [Section 4.3.1, "Identify Device command"](#) (words 60-61 and 100-103) for additional information about 48-bit addressing support of drives with capacities over 137GB.

2.3 Default logical geometry

- **Cylinders:** 16,383
- **Read/write heads:** 16
- **Sectors per track:** 63

LBA mode

When addressing these drives in LBA mode, all blocks (sectors) are consecutively numbered from 0 to $n-1$, where n is the number of guaranteed sectors as defined above.

2.4 Recording and interface technology

Models	6TB & 3TB	8TB, 4TB & 2TB
Interface	SATA	
Recording method	SMR	
Recording density (kBPI)	2197	
Track density (ktracks/inch avg)	540	
Areal density (Gb/in ²)	900	1186
Interface transfer rate (MB/s)	600	
Data transfer rate (MB/s)	up to 180	

2.5 Physical characteristics

Height	
8TB & 6TB	26.1mm / 1.028 in (max)
2TB, 3TB & 4TB	20.20mm / 0.795 in (max)
Width	101.6mm (± 0.25) / 4.0 in (± 0.010 in)
Length	146.99mm / 5.787 in (max)
Typical weight	
8TB	630g / 1.389 lb
6TB	610g / 1.345 lb
3TB & 4TB	490g / 1.08 lb
2TB	415g / 0.915 lb
Cache buffer	256MB

2.6 Start/stop times

The start/stop times are listed below.

	8TB & 6TB models	4TB & 3TB models	2TB models
Power-on to ready (in seconds)	15 (typical)	10 (typical)	8 (typical)
Standby to ready (in seconds)	15 (typical)	10 (typical)	8 (typical)
Ready to spindle stop (in seconds)	18 (typical)	12 (typical)	10 (typical)

Time-to-ready may be longer than normal if the drive power is removed without going through normal OS powerdown procedures.

2.7 Power specifications

The drive receives DC power (+5V or +12V) through a native SATA power connector. Refer to [Figure 2 on page 18](#).

2.7.1 Power consumption

Power requirements for the drives are listed in [Table 2](#) and [Table 3](#). Typical power measurements are based on an average of drives tested, under nominal conditions, using 5.0V and 12.0V input voltage at 25°C ambient temperature. These power measurements are done with DIPM enabled.

- Spinup current is measured from the time of power-on to the time that the drive spindle reaches operating speed.
- Operating Power is measured following IDEMA 3 streams standard, assuming CE operating condition
- The drive supports three idle modes: Performance Idle mode, Active Idle mode and Low Power Idle mode. Refer to [Section 2.7.4](#) for power-management mode.

Table 2 DC power requirements (8TB & 6TB)

Power dissipation	Avg (watts 25° C)	Avg 5V typ amps	Avg 12V typ amps
Spinup	—	—	1.8
Idle, Low Power	3.4	0.10	0.242
Operating Power	5.3	0.28	0.325
Standby	0.25	0.04	0.004
Sleep	0.25	0.04	0.004

Table 3 DC power requirements (4TB, 3TB & 2TB)

Power dissipation	Avg (watts 25° C)	Avg 5V typ amps	Avg 12V typ amps
Spinup	—	—	1.8
Idle, Low Power	2.5	0.12	0.15
Operating Power	3.7	0.28	0.191
Standby	0.25	0.04	0.004
Sleep	0.25	0.04	0.004

2.7.2 Conducted noise

Input noise ripple is measured at the host system power supply across an equivalent 80-ohm resistive load on the +12 volt line or an equivalent 15-ohm resistive load on the +5 volt line.

- Using 12-volt power, the drive is expected to operate with a maximum of 120 mV peak-to-peak square-wave injected noise at up to 10MHz.
- Using 5-volt power, the drive is expected to operate with a maximum of 100 mV peak-to-peak square-wave injected noise at up to 10MHz.

Note

Equivalent resistance is calculated by dividing the nominal voltage by the typical RMS read/write current.

2.7.3 Voltage tolerance

Voltage tolerance (including noise):

- 5VDC $\pm 5\%$
- 12VDC $\pm 10\%$

2.7.4 Power-management modes

The drive provides programmable power management to provide greater energy efficiency. In most systems, users can control power management through the system setup program. The drive features the following power-management modes:

Power modes	Heads	Spindle	Electronics
Active	Tracking	Rotating	Full Power
Idle, Performance	Tracking	Rotating	Full Power
Idle, Active	Floating	Rotating	Partial Power
Idle, Low Power	Parked	Rotating	Partial Power
Standby	Parked	Stopped	Low Power
Sleep	Parked	Stopped	Low Power

- **Active mode**

The drive is in Active mode during the read/write and seek operations.

- **Idle mode**

The electronics remain powered, and the drive accepts all commands and returns to Active mode when disk access is necessary.

- **Standby mode**

The drive enters Standby mode immediately when the host sends a Standby Immediate command. If the host has set the standby timer, the drive enters Standby mode automatically after the drive has been inactive for a specifiable length of time. The standby timer delay is established using a Standby or Idle command. In Standby mode, the electronics are in low power mode, the heads are parked and the spindle is at rest. The drive accepts all commands and returns to Active mode when disk access is necessary.

- **Sleep mode**

The drive enters Sleep mode after receiving a Sleep command from the host. In Sleep mode, the electronics are in low power mode, the heads are parked and the spindle is at rest. The drive leaves Sleep mode after it receives a Hard Reset or Soft Reset from the host. After receiving a reset, the drive exits Sleep mode and enters Standby mode.

- **Idle and Standby timers**

Each time the drive performs an Active function (read, write or seek), the standby timer is reinitialized and begins counting down from its specified delay times to zero. If the standby timer reaches zero before any drive activity is required, the drive makes a transition to Standby mode. In both Idle and Standby mode, the drive accepts all commands and returns to Active mode when disk access is necessary.

2.8 Environmental specifications

This section provides the temperature, humidity, shock, and vibration specifications for SkyHawk drives. Ambient temperature is defined as the temperature of the environment immediately surrounding the drive. Above 1000ft. (305 meters), the maximum temperature is derated linearly by 1°C every 1000 ft. Refer to [Section 3.4 on page 19](#) for base plate measurement location.

2.8.1 Ambient Temperature

Non-operating (Ambient)	-40° to 70°C (-40° to 158°F)
Operating ambient (min °C)	0° (32°F)
Operating (Drive case max °C)	70° (158°F) †

† Seagate does not recommend operating at sustained case temperatures above 60°C. Operating at higher temperatures will reduce useful life of the product.

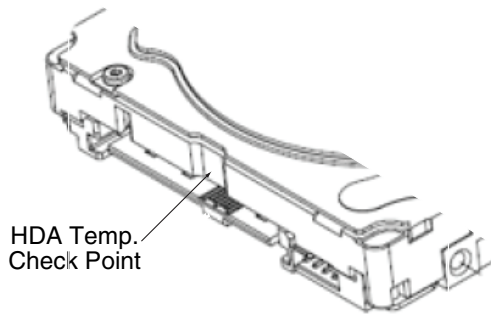

Figure 1 Location of the HDA temperature check point

Note Image is for reference only, may not represent actual drive.

2.8.2 Temperature gradient

Operating	20°C per hour (36°F per hour max), without condensation
Non-operating	30°C per hour (54°F per hour max)

2.8.3 Humidity

2.8.3.1 Relative humidity

Operating	5% to 90% non-condensing (30% per hour max)
non-operating	5% to 95% non-condensing (30% per hour max)

2.8.3.2 Wet bulb temperature

Operating	30°C / 86°F (rated)
Non-operating	40°C / 104°F (rated)

2.8.4 Altitude

Operating	-304m to 3048m (-1000 ft. to 10,000 ft.)
Non-operating	-304m to 12,192m (-1000 ft. to 40,000+ ft.)

2.8.5 Shock

All shock specifications assume that the drive is mounted securely with the input shock applied at the drive mounting screws. Shock may be applied in the X, Y or Z axis.

2.8.5.1 Operating shock

These drives comply with the performance levels specified in this document when subjected to a maximum operating shock of 80 Gs (read) / 70 Gs (write) based on half-sine shock pulses of 2ms during read operations. Shocks should not be repeated more than two times per second.

2.8.5.2 Non-operating shock

The non-operating shock level that the drive can experience without incurring physical damage or degradation in performance when subsequently put into operation is 300 Gs based on a non-repetitive half-sine shock pulse of 2ms duration.

2.8.6 Vibration

All vibration specifications assume that the drive is mounted securely with the input vibration applied at the drive mounting screws. Vibration may be applied in the X, Y or Z axis. Throughput may vary if improperly mounted.

2.8.6.1 Operating vibration

The maximum vibration levels that the drive may experience while meeting the performance standards specified in this document are specified below.

10Hz to 22Hz	0.25 Gs (Limited displacement)
22Hz to 350Hz	0.50 Gs
350Hz to 500Hz	0.25 Gs

2.8.6.2 Non-operating vibration

The maximum non-operating vibration levels that the drive may experience without incurring physical damage or degradation in performance when subsequently put into operation are specified below.

5Hz to 22Hz	3.0 Gs (Limited displacement)
22Hz to 350Hz	3.0 Gs
350Hz to 500Hz	3.0 Gs

2.9 Acoustics

Drive acoustics are measured as overall A-weighted acoustic sound power levels (no pure tones). All measurements are consistent with ISO document 7779. Sound power measurements are taken under essentially free-field conditions over a reflecting plane. For all tests, the drive is oriented with the cover facing upward.

Note	For seek mode tests, the drive is placed in seek mode only. The number of seeks per second is defined by the following equation: (Number of seeks per second = $0.4 / (\text{average latency} + \text{average access time})$)
-------------	--

Table 4 Fluid Dynamic Bearing (FDB) motor acoustics

	Idle*	Seek
All models	2.6 bels (typical) 2.7 bels (max)	2.7 bels (typical) 2.8 bels (max)

*During periods of drive idle, some offline activity may occur according to the S.M.A.R.T. specification, which may increase acoustic and power to operational levels.

2.9.1 Test for Prominent Discrete Tones (PDTs)

Seagate follows the ECMA-74 standards for measurement and identification of PDTs. An exception to this process is the use of the absolute threshold of hearing. Seagate uses this threshold curve (originated in ISO 389-7) to discern tone audibility and to compensate for the inaudible components of sound prior to computation of tone ratios according to Annex D of the ECMA-74 standards.

2.10 Electromagnetic immunity

When properly installed in a representative host system, the drive operates without errors or degradation in performance when subjected to the radio frequency (RF) environments defined in [Table 5](#).

Table 5 Radio frequency environments

Test	Description	Performance level	Reference standard
Electrostatic discharge	Contact, HCP, VCP: ± 4 kV; Air: ± 8 kV	B	EN61000-4-2: 95
Radiated RF immunity	80MHz to 1,000MHz, 3 V/m, 80% AM with 1kHz sine 900MHz, 3 V/m, 50% pulse modulation @ 200Hz	A	EN61000-4-3: 96 ENV50204: 95
Electrical fast transient	± 1 kV on AC mains, ± 0.5 kV on external I/O	B	EN61000-4-4: 95
Surge immunity	± 1 kV differential, ± 2 kV common, AC mains	B	EN61000-4-5: 95
Conducted RF immunity	150kHz to 80MHz, 3 Vrms, 80% AM with 1kHz sine	A	EN61000-4-6: 97
Voltage dips, interrupts	0% open, 5 seconds 0% short, 5 seconds 40%, 0.10 seconds 70%, 0.01 seconds	C C C B	EN61000-4-11: 94

2.11 Warranty

To determine the warranty for a specific drive, use a web browser to access the following web page:

<http://www.seagate.com/support/warranty-and-replacements/>

From this page, click on “Is my Drive under Warranty”. Users will be asked to provide the drive serial number, model number (or part number) and country of purchase. The system will display the warranty information for the drive.

2.11.1 Data loss under power interruption with write cache enabled

Drive preserves its data during all operations except in cases where power to the drive is interrupted during write operations. This could result in either an uncorrected data error being reported, or the entire sector/track becoming unreadable. This can be permanently recovered by rewriting to the same location on the drive. Additionally any data present in the DRAM buffer will not be written to the disk media, additionally, the drive will not be able to return the original data.

In order to prevent this data loss, the host should issue a standby immediate or flush cache command before a controlled power off operation to the drive.

2.11.2 Storage

Maximum storage periods are 180 days within original unopened Seagate shipping package or 60 days unpackaged within the defined non-operating limits (refer to environmental section in this manual). Storage can be extended to 1 year packaged or unpackaged under optimal environmental conditions (25°C, <40% relative humidity non-condensing, and non-corrosive environment). During any storage period the drive non-operational temperature, humidity, wet bulb, atmospheric conditions, shock, vibration, magnetic and electrical field specifications should be followed.

2.11.3 HDD and SSD Regulatory Compliance and Safety

For the latest regulatory and compliance information see: <https://www.seagate.com/support/> scroll to bottom of page and click the Seagate HDD and SSD Regulatory Compliance and Safety link.

2.11.4 Safety certification

The drives are recognized in accordance with UL/cUL 60950-1 and EN 60950-1.

The following regulatory model numbers represent all features and configurations within the series:

SKR002: 1/2D (4TB, 3TB & 2TB Models)

SKR004: 3/4D (8TB & 6TB Models)

2.12 Corrosive environment

Seagate electronic drive components pass accelerated corrosion testing equivalent to 10 years exposure to light industrial environments containing sulfurous gases, chlorine and nitric oxide, classes G and H per ASTM B845. However, this accelerated testing cannot duplicate every potential application environment. Users should use caution exposing any electronic components to uncontrolled chemical pollutants and corrosive chemicals as electronic drive component reliability can be affected by the installation environment. The silver, copper, nickel and gold films used in Seagate products are especially sensitive to the presence of sulfide, chloride, and nitrate contaminants. Sulfur is found to be the most damaging. In addition, electronic components should never be exposed to condensing water on the surface of the printed circuit board assembly (PCBA) or exposed to an ambient relative humidity greater than 95%. Materials used in cabinet fabrication, such as vulcanized rubber, that can outgas corrosive compounds should be minimized or eliminated. The useful life of any electronic equipment may be extended by replacing materials near circuitry with sulfide-free alternatives.

3.0 Configuring and Mounting the Drive

This section contains the specifications and instructions for configuring and mounting the drive.

3.1 Handling and static-discharge precautions

After unpacking, and before installation, the drive may be exposed to potential handling and electrostatic discharge (ESD) hazards. Observe the following standard handling and static-discharge precautions:

Caution

- Before handling the drive, put on a grounded wrist strap, or ground oneself frequently by touching the metal chassis of a computer that is plugged into a grounded outlet. Wear a grounded wrist strap throughout the entire installation procedure.
- Handle the drive by its edges or frame *only*.
- The drive is extremely fragile—handle it with care. Do not press down on the drive top cover.
- Always rest the drive on a padded, antistatic surface until users mount it in the computer.
- Do not touch the connector pins or the printed circuit board.
- Do not remove the factory-installed labels from the drive or cover them with additional labels. Removal voids the warranty. Some factory-installed labels contain information needed to service the drive. Other labels are used to seal out dirt and contamination.

3.2 Configuring the drive

Each drive on the SATA interface connects point-to-point with the SATA host adapter. There is no master/slave relationship because each drive is considered a master in a point-to-point relationship. If two drives are attached on one SATA host adapter, the host operating system views the two devices as if they were both “masters” on two separate ports. Both drives behave as if they are Device 0 (master) devices.

SATA drives are designed for easy installation. It is usually not necessary to set any jumpers on the drive for proper operation; however, if users connect the drive and receive a “drive not detected” error, the SATA-equipped motherboard or host adapter may use a chipset that does not support SATA speed autonegotiation.

3.3 SATA cables and connectors

The SATA interface cable consists of four conductors in two differential pairs, plus three ground connections. The cable size may be 30 to 26 AWG with a maximum length of one meter (39.37 inches). See [Table 6](#) for connector pin definitions. Either end of the SATA signal cable can be attached to the drive or host.

For direct backplane connection, the drive connectors are inserted directly into the host receptacle. The drive and the host receptacle incorporate features that enable the direct connection to be hot pluggable and blind mateable.

For installations which require cables, users can connect the drive as illustrated in [Figure 2](#).

Figure 2 Attaching SATA cabling

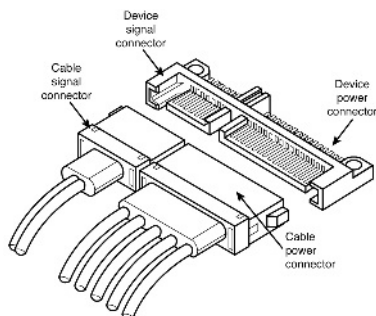

Each cable is keyed to ensure correct orientation. SkyHawk drives support latching SATA connectors.

3.4 Drive mounting

Users can mount the drive in any orientation using four screws in the side-mounting holes or four screws in the bottom-mounting holes. Refer to **Figure 3** for drive mounting dimensions. Follow these important mounting precautions when mounting the drive:

- Allow a minimum clearance of 0.030 inches (0.76mm) around the entire perimeter of the drive for cooling.
- Use only 6-32 UNC mounting screws.
- The screws should be inserted no more than 0.140 inch (3.56mm) into the bottom or side mounting holes.
- Do not overtighten the mounting screws (maximum torque: 6 inch-lb).

Figure 3 Mounting dimensions (4TB, 3TB & 2TB models)

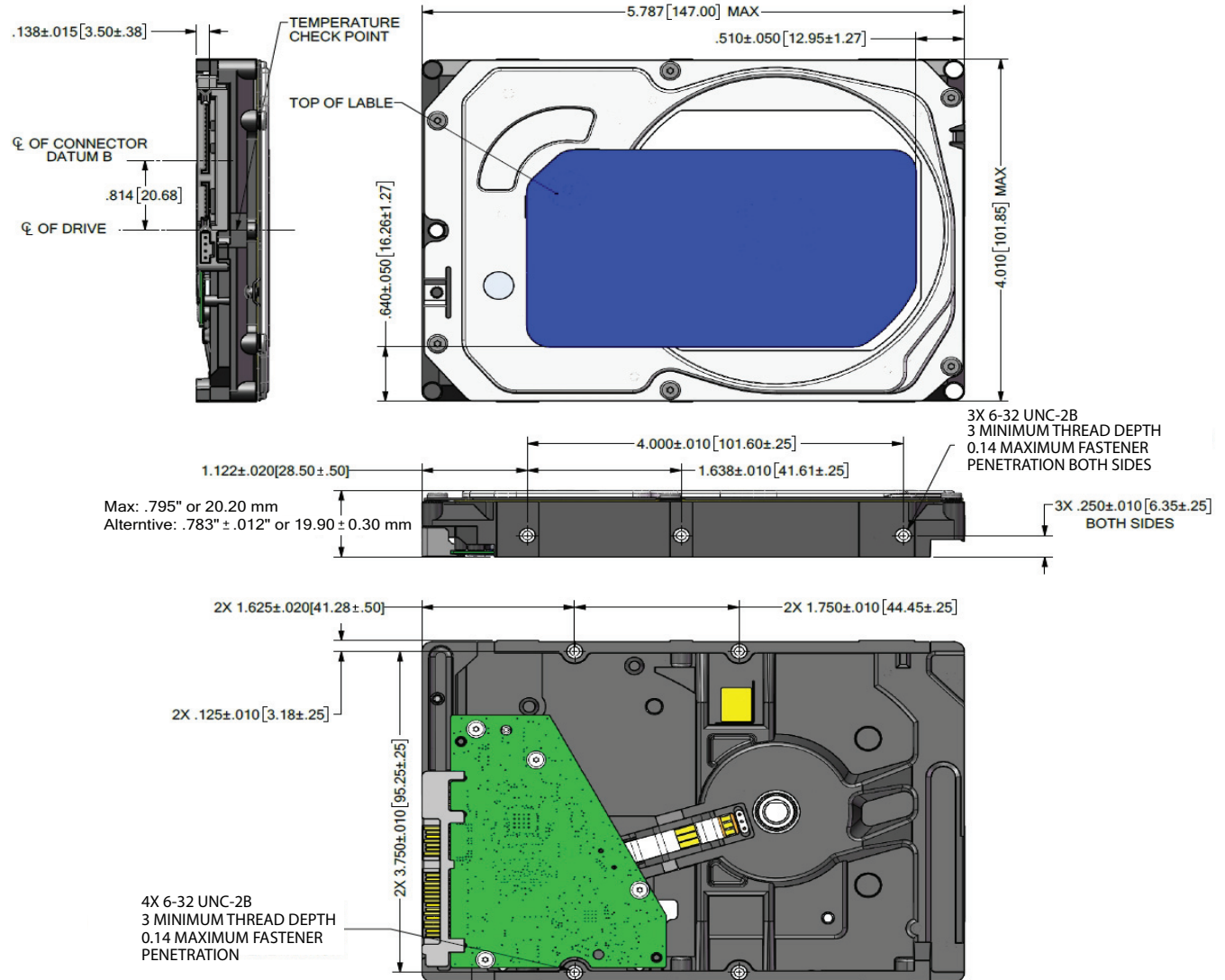
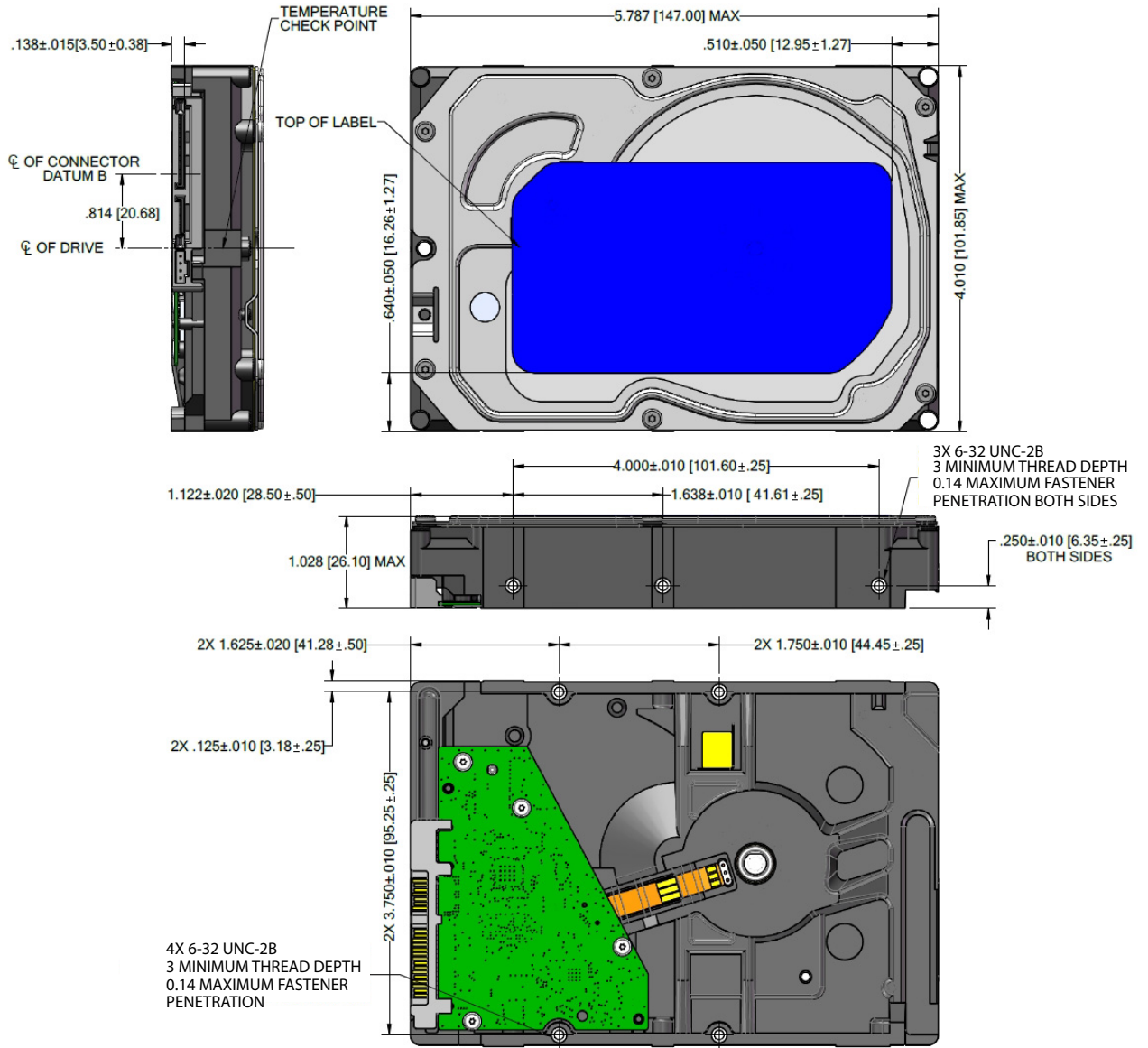

Figure 4 Mounting dimensions (8TB & 6TB models)



4.0 SATA Interface

These drives use the industry-standard Serial ATA (SATA) interface that supports FIS data transfers. It supports ATA programmed input/output (PIO) modes 0 to 4; multiword DMA modes 0 to 2, and Ultra DMA modes 0 to 6.

For detailed information about the SATA interface, refer to the “Serial ATA: High Speed Serialized AT Attachment” specification.

4.1 Hot-Plug compatibility

SkyHawk drives incorporate connectors which enable users to hot plug these drives in accordance with the SATA Revision 3.2 specification. This specification can be downloaded from www.serialata.org.

4.2 SATA device plug connector pin definitions

Table 6 summarizes the signals on the SATA interface and power connectors.

Table 6 SATA connector pin definitions

Segment	Pin	Function	Definition
Signal	S1	Ground	2nd mate
	S2	A+	Differential signal pair A from Phy
	S3	A-	
	S4	Ground	2nd mate
	S5	B-	Differential signal pair B from Phy
	S6	B+	
	S7	Ground	2nd mate
Key and spacing separate signal and power segments			
Power	P1	V ₃₃	3.3V power
	P2	V ₃₃	3.3V power
	P3	V ₃₃	3.3V power, pre-charge, 2nd mate
	P4	Ground	1st mate
	P5	Ground	2nd mate
	P6	Ground	2nd mate
	P7	V ₅	5V power, pre-charge, 2nd mate
	P8	V ₅	5V power
	P9	V ₅	5V power
	P10	Ground	2nd mate
	P11	Ground or LED signal	If grounded, drive does not use deferred spin
	P12	Ground	1st mate.
	P13	V ₁₂	12V power, pre-charge, 2nd mate
	P14	V ₁₂	12V power
	P15	V ₁₂	12V power

Notes

- All pins are in a single row, with a 1.27 mm (0.050 in) pitch.
- The comments on the mating sequence apply to the case of backplane blindmate connector only. In this case, the mating sequences are:
 - the ground pins P4 and P12.
 - the pre-charge power pins and the other ground pins.
 - the signal pins and the rest of the power pins.
- There are three power pins for each voltage. One pin from each voltage is used for pre-charge when installed in a blind-mate backplane configuration.
 - All used voltage pins (V_x) must be terminated.

4.3 Supported ATA commands

The following table lists SATA standard commands that the drive supports.

For a detailed description of the ATA commands, refer to the Serial ATA International Organization: Serial ATA Revision 3.0 (<http://www.sata-io.org>).

See “S.M.A.R.T. commands” on page 30 for details and subcommands used in the S.M.A.R.T. implementation.

Table 7 SATA standard commands

Command name	Command code (in hex)
Check Power Mode	E5 _H
Device Configuration Freeze Lock	B1 _H / C1 _H
Device Configuration Identify	B1 _H / C2 _H
Device Configuration Restore	B1 _H / C0 _H
Device Configuration Set	B1 _H / C3 _H
Device Reset	08 _H
Download Microcode	92 _H
Execute Device Diagnostics	90 _H
Flush Cache	E7 _H
Flush Cache Extended	EA _H
Format Track	50 _H
Identify Device	EC _H
Idle	E3 _H
Idle Immediate	E1 _H
Initialize Device Parameters	91 _H
Read Buffer	E4 _H
Read DMA	C8 _H
Read DMA Extended	25 _H
Read DMA Without Retries	C9 _H
Read Log Ext	2F _H
Read Multiple	C4 _H
Read Multiple Extended	29 _H
Read Native Max Address	F8 _H
Read Native Max Address Extended	27 _H
Read Sectors	20 _H
Read Sectors Extended	24 _H
Read Sectors Without Retries	21 _H
Read Verify Sectors	40 _H
Read Verify Sectors Extended	42 _H
Read Verify Sectors Without Retries	41 _H
Recalibrate	10 _H
Security Disable Password	F6 _H
Security Erase Prepare	F3 _H
Security Erase Unit	F4 _H
Security Freeze	F5 _H
Security Set Password	F1 _H

Table 7 SATA standard commands (continued)

Command name	Command code (in hex)	
Security Unlock	F2 _H	
Seek	70 _H	
Set Features	EF _H	
Set Max Address	F9 _H	
Note: Individual Set Max Address commands are identified by the value placed in the Set Max Features register as defined to the right.	Address:	00H
	Password:	01H
	Lock:	02H
	Unlock:	03H
	Freeze Lock:	04H
Set Max Address Extended	37 _H	
Set Multiple Mode	C6 _H	
Sleep	E6 _H	
S.M.A.R.T. Disable Operations	B0 _H / D9 _H	
S.M.A.R.T. Enable/Disable Autosave	B0 _H / D2 _H	
S.M.A.R.T. Enable Operations	B0 _H / D8 _H	
S.M.A.R.T. Execute Offline	B0 _H / D4 _H	
S.M.A.R.T. Read Attribute Thresholds	B0 _H / D1 _H	
S.M.A.R.T. Read Data	B0 _H / D0 _H	
S.M.A.R.T. Read Log Sector	B0 _H / D5 _H	
S.M.A.R.T. Return Status	B0 _H / DA _H	
S.M.A.R.T. Save Attribute Values	B0 _H / D3 _H	
S.M.A.R.T. Write Log Sector	B0 _H / D6 _H	
Standby	E2 _H	
Standby Immediate	E0 _H	
Write Buffer	E8 _H	
Write DMA	CA _H	
Write DMA Extended	35 _H	
Write DMA FUA Extended	3D _H	
Write DMA Without Retries	CB _H	
Write Log Extended	3F _H	
Write Multiple	C5 _H	
Write Multiple Extended	39 _H	
Write Multiple FUA Extended	CE _H	
Write Sectors	30 _H	
Write Sectors Without Retries	31 _H	
Write Sectors Extended	34 _H	
Write Uncorrectable	45 _H	

4.3.1 Identify Device command

The Identify Device command (command code EC_H) transfers information about the drive to the host following power up. The data is organized as a single 512-byte block of data, whose contents are shown in **Table 7 on page 22**. All reserved bits or words should be set to zero. Parameters listed with an “x” are drive-specific or vary with the state of the drive.

The following commands contain drive-specific features that may not be included in the SATA specification.

Table 8 Identify Device commands

Word	Description	Value
0	Configuration information: <ul style="list-style-type: none"> • Bit 15: 0 = ATA; 1 = ATAPI • Bit 7: removable media • Bit 6: removable controller • Bit 0: reserved 	0C5A _H
1	Number of logical cylinders	16,383
2	Specific configuration: <p>37C8h Device requires SET FEATURES subcommand to spin-up after power-up and IDENTIFY DEVICE data is incomplete.</p> <p>738Ch Device requires SET FEATURES subcommand to spin-up after power-up and IDENTIFY DEVICE data is complete.</p> <p>8C73h Device does not require SET FEATURES subcommand to spin-up after power-up and IDENTIFY DEVICE data is incomplete.</p> <p>C837h Device does not require SET FEATURES subcommand to spin-up after power-up and IDENTIFY DEVICE data is complete.</p>	C837 _H
3	Number of logical heads	16
4	Retired	0000 _H
5	Retired	0000 _H
6	Number of logical sectors per logical track: 63	003F _H
7–9	Retired	0000 _H
10–19	Serial number: (20 ASCII characters, 0000 _H = none)	ASCII
20	Retired	0000 _H
21	Retired	0400 _H
22	Obsolete	0000 _H
23–26	Firmware revision (8 ASCII character string, padded with blanks to end of string)	x.xx
27–46	Drive model number: (40 ASCII characters, padded with blanks to end of string)	
47	(Bits 7–0) Maximum sectors per interrupt on Read multiple and Write multiple (16)	8010 _H
48	Trusted Computing feature set options: <ul style="list-style-type: none"> 15 Shall be cleared to zero 14 Shall be set to one 13:1 Reserved for the Trusted Computing Group 0 Trusted Computing feature set is supported 	4000 _H
49	Standard Standby timer, IORDY supported and may be disabled	2F00 _H
50	Capabilities: (see 7.17.7.17) <ul style="list-style-type: none"> 15 Shall be cleared to zero 14 Shall be set to one 13:2 Reserved 1 Obsolete 0 Shall be set to one to indicate a vendor specific Standby timer value minimum 	4000 _H

Table 8 Identify Device commands (continued)

Word	Description	Value
51	PIO data-transfer cycle timing mode	0200 _H
52	Retired (Obsolete)	0200 _H
53	15:8 Free-fall Control Sensitivity 7:3 Reserved 2 the fields reported in word 88 are valid 1 the fields reported in words (70:64) are valid 0 Obsolete	0007 _H
54	Number of current logical cylinders (Obsolete)	xxxx _H
55	Number of current logical heads (Obsolete)	xxxx _H
56	Number of current logical sectors per logical track (Obsolete)	xxxx _H
57–58	Current capacity in sectors (Obsolete)	xxxx _H
59	15 The BLOCK ERASE EXT command is supported 14 The OVERWRITE EXT command is supported 13 The CRYPTO SCRAMBLE EXT command is supported 12 The Sanitize feature set is supported 11:9 Reserved 8 Multiple logical sector setting is valid 7:0 Current setting for number of logical sectors that shall be transferred per DRQ data block on READ/WRITE Multiple commands	5C10 _H
60–61	Total number of user-addressable LBA sectors available (see Section 2.2 for related information) *Note: The maximum value allowed in this field is: 0FFFFFFFh (268,435,455 sectors, 137GB). Drives with capacities over 137GB will have 0FFFFFFFh in this field and the actual number of user-addressable LBAs specified in words 100-103. This is required for drives that support the 48-bit addressing feature.	0FFFFFFFh*
62	Obsolete	0000 _H
63	Multiword DMA active and modes supported (see note following this table)	xx07 _H
64	Advanced PIO modes supported (modes 3 and 4 supported)	0003 _H
65	Minimum multiword DMA transfer cycle time per word (120 nsec)	0078 _H
66	Recommended multiword DMA transfer cycle time per word (120 nsec)	0078 _H
67	Minimum PIO cycle time without IORDY flow control (240 nsec)	0078 _H
68	Minimum PIO cycle time with IORDY flow control (120 nsec)	0078 _H
69	Additional Supported 15 CFAST Specification Support 14 Deterministic data in trimmed LBA range(s) is supported 13 Long Physical Sector Alignment Error Reporting Control is supported 12 Obsolete 11 READ BUFFER DMA is supported 10 WRITE BUFFER DMA is supported 9 Obsolete 8 DOWNLOAD MICROCODE DMA is supported 7 Reserved for IEEE 1667 6 0 = Optional ATA device 28-bit commands supported 5 Trimmed LBA range(s) returning zeroed data is supported 4 Device Encrypts All User Data 3 Extended Number of User Addressable Sectors is supported 2 All write cache is non-volatile 1:0 Reserved	0000 _H

Table 8 Identify Device commands (continued)

Word	Description	Value
70–74	ATA-reserved	0000 _H
75	Queue depth	001F _H
76	SATA capabilities	xxxx _H
77	Reserved for future SATA definition	xxxx _H
78	SATA features supported	xxxx _H
79	SATA features enabled	xxxx _H
80	Major version number	07F0 _H
81	Minor version number	006D _H
82	Command sets supported	306B _H
83	Command sets supported	7561 _H
84	Command sets support extension (see note following this table)	6173 _H
85	Command sets enabled	30xx _H
86	Command sets enabled	B441 _H
87	Command sets enable extension	6173 _H
88	Ultra DMA support and current mode (see note following this table)	xx7F _H
89	Security erase time	xxxx _H
90	Enhanced security erase time	xxxx _H
92	Master password revision code	FFFE _H
93	Hardware reset value	xxxx _H
94	Automatic acoustic management	D0D0 _H
95–99	ATA-reserved	0000 _H
100–103	Total number of user-addressable LBA sectors available (see Section 2.2 for related information). These words are required for drives that support the 48-bit addressing feature. Maximum value: 0000FFFFFFFFF _H .	8TB models = 15,628,053,168 6TB models = 11,721,045,168 4TB models = 7,814,037,168 3TB models = 5,860,533,168 2TB models = 3,907,029,168
104-105	ATA-reserved	0000 _H
106	Physical sector size / logical sector size	6003 _H
107	ATA-reserved	0000 _H
108-111	The mandatory value of the world wide name (WWN) for the drive. NOTE: This field is valid if word 84, bit 8 is set to 1 indicating 64-bit WWN support.	Each drive will have a unique value.
112-118	ATA-reserved	0000 _H
119	Commands and feature sets supported	41DE _H
120	Commands and feature sets supported or enabled	409C _H
121-127	ATA-reserved	0000 _H
128	Security status	0021 _H
129–159	Seagate-reserved	xxxx _H
160–167	ATA-reserved	0000 _H
168	Device Nominal Form Factor	0002 _H

Table 8 Identify Device commands (continued)

Word	Description	Value
169-205	ATA-reserved	0000 _H
206	SCT Command Transport	10A5 _H
207-208	ATA-reserved	0000 _H
209	Alignment of logical blocks within a physical block	4000 _H
210-216	ATA-reserved	0000 _H
217	Nominal media rotation rate	175C _H
218-221	ATA-reserved	0000 _H
222	Transport major version number	107F _H
223-229	ATA-reserved	0000 _H
230-233	Extended Number of User Addressable Sectors	8TB models = 15,628,053,168 6TB models = 11,721,045,168 4TB models = 7,814,037,168 3TB models = 5,860,533,168 2TB models = 3,907,029,168
234-254	ATA-reserved	0000 _H
255	Integrity word	xxA5 _H

Note	Advanced Power Management (APM) and Automatic Acoustic Management (AAM) features are not supported.
-------------	---

Note	See the bit descriptions below for words 63, 84, and 88 of the Identify Drive data.
-------------	---

Description (if bit is set to 1)	
	Bit Word 63
0	Multiword DMA mode 0 is supported.
1	Multiword DMA mode 1 is supported.
2	Multiword DMA mode 2 is supported.
8	Multiword DMA mode 0 is currently active.
9	Multiword DMA mode 1 is currently active.
10	Multiword DMA mode 2 is currently active.
	Bit Word 84
0	SMART error login is supported.
1	SMART self-test is supported.
2	Media serial number is supported.
3	Media Card Pass Through Command feature set is supported.
4	Streaming feature set is supported.
5	GPL feature set is supported.
6	WRITE DMA FUA EXT and WRITE MULTIPLE FUA EXT commands are supported.
7	WRITE DMA QUEUED FUA EXT command is supported.
8	64-bit World Wide Name is supported.
9-10	Obsolete.
11-12	Reserved for TLC.
13	IDLE IMMEDIATE command with IUNLOAD feature is supported.
14	Shall be set to 1.
15	Shall be cleared to 0.
	Bit Word 88
0	Ultra DMA mode 0 is supported.
1	Ultra DMA mode 1 is supported.
2	Ultra DMA mode 2 is supported.
3	Ultra DMA mode 3 is supported.
4	Ultra DMA mode 4 is supported.
5	Ultra DMA mode 5 is supported.
6	Ultra DMA mode 6 is supported.
8	Ultra DMA mode 0 is currently active.
9	Ultra DMA mode 1 is currently active.
10	Ultra DMA mode 2 is currently active.
11	Ultra DMA mode 3 is currently active.
12	Ultra DMA mode 4 is currently active.
13	Ultra DMA mode 5 is currently active.
14	Ultra DMA mode 6 is currently active.

4.3.2 Set Features command

This command controls the implementation of various features that the drive supports. When the drive receives this command, it sets BSY, checks the contents of the Features register, clears BSY and generates an interrupt. If the value in the register does not represent a feature that the drive supports, the command is aborted. Power-on default has the read look-ahead and write caching features enabled. The acceptable values for the Features register are defined as follows:

Table 9 Set Features command

02 _H	Enable write cache (<i>default</i>)
03 _H	Set transfer mode (based on value in Sector Count register) Sector Count register values:
	00 _H Set PIO mode to default (PIO mode 2)
	01 _H Set PIO mode to default and disable IORDY (PIO mode 2)
	08 _H PIO mode 0
	09 _H PIO mode 1
	0A _H PIO mode 2
	0B _H PIO mode 3
	0C _H PIO mode 4 (<i>default</i>)
	20 _H Multiword DMA mode 0
	21 _H Multiword DMA mode 1
	22 _H Multiword DMA mode 2
	40 _H Ultra DMA mode 0
	41 _H Ultra DMA mode 1
	42 _H Ultra DMA mode 2
	43 _H Ultra DMA mode 3
	44 _H Ultra DMA mode 4
	45 _H Ultra DMA mode 5
	46 _H Ultra DMA mode 6
06 _H	Enable the PUIS feature set
07 _H	PUIS feature set device spin-up
10 _H	Enable use of SATA features
55 _H	Disable read look-ahead (read cache) feature
82 _H	Disable write cache
86 _H	Disable the PUIS feature set
90 _H	Disable use of SATA features
AA _H	Enable read look-ahead (read cache) feature (<i>default</i>)
F1 _H	Report full capacity available

Note

At power-on, or after a hardware or software reset, the default values of the features are as indicated above.

4.3.3 S.M.A.R.T. commands

S.M.A.R.T. provides near-term failure prediction for disk drives. When S.M.A.R.T. is enabled, the drive monitors predetermined drive attributes that are susceptible to degradation over time. If self-monitoring determines that a failure is likely, S.M.A.R.T. makes a status report available to the host. Not all failures are predictable. S.M.A.R.T. predictability is limited to the attributes the drive can monitor. For more information on S.M.A.R.T. commands and implementation, see the *Draft ATA-5 Standard*.

SeaTools diagnostic software activates a built-in drive self-test (DST S.M.A.R.T. command for D4_H) that eliminates unnecessary drive returns. The diagnostic software ships with all new drives and is also available at: <http://seatools.seagate.com>.

This drive is shipped with S.M.A.R.T. features disabled. Users must have a recent BIOS or software package that supports S.M.A.R.T. to enable this feature. The table below shows the S.M.A.R.T. command codes that the drive uses.

Table 10 S.M.A.R.T. commands

Code in features register	S.M.A.R.T. command
D0 _H	S.M.A.R.T. Read Data
D2 _H	S.M.A.R.T. Enable/Disable Attribute Autosave
D3 _H	S.M.A.R.T. Save Attribute Values
D4 _H	S.M.A.R.T. Execute Off-line Immediate (runs DST)
D5 _H	S.M.A.R.T. Read Log Sector
D6 _H	S.M.A.R.T. Write Log Sector
D8 _H	S.M.A.R.T. Enable Operations
D9 _H	S.M.A.R.T. Disable Operations
DA _H	S.M.A.R.T. Return Status

Note	If an appropriate code is not written to the Features Register, the command is aborted and 0x04 (abort) is written to the Error register.
-------------	---



Seagate Technology LLC

AMERICAS Seagate Technology LLC 47488 Kato Road, Fremont, California 94538, United States, 510-661-1000